



e-BoX

The electric Faber e-BoX series has been developed especially for true fire connoisseurs who are looking for a complete and 100% future-proof alternative to an atmospheric gas or wood fire, and who value a good price-quality ratio. The new Faber e-BoX series provides a unique solution for the full enjoyment of a swirling, atmospheric fire, without the traditional limitations that may be associated with a built-in gas or wood fire. For example, limitations because of the living environment (city), apartment blocks, the lack of a connection to the gas grid or a chimney, or because there is no room to build in a fire.

e-BoX | 1000/450 |



DECORATION OPTIONS



More product information?



Heating functionality:	Yes
Flue material:	-
Watts:	1400 W
Volts:	230-240 V
Water consumption:	0,3 l/h
Water pressure:	0,5-8 Bar
Water connection:	1/2" - 1/4"



Specifications

Exterior dimensions WxHxD in mm

1140 x 800 x 405

Fire display WxHxD in mm

1032 x 368

System

e-BoX burner

Decoration

Log set / White Pebble / Acrylic Ice

Back walls

Back wall smooth steel

Remote

Bluetooth remote

Power

1,0 kW

Operating system

-

Energy label

-

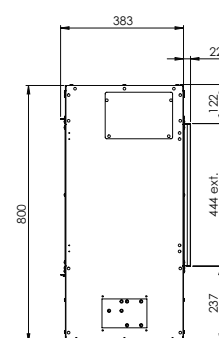
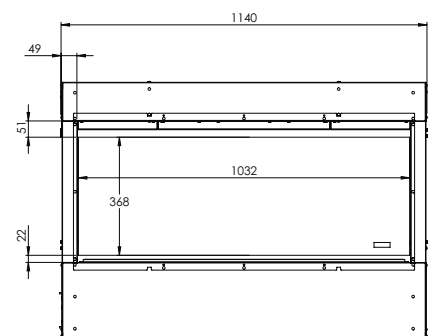
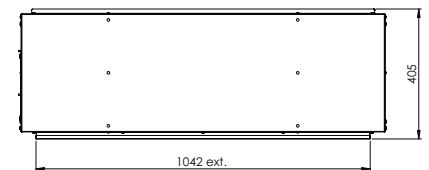

There is **so much to tell...**